



Edinburgh Pathway Notation

S Moodie, A Sorokin, I Goryanin , P Ghazal

SBGN-1

Edinburgh Centre for
Bioinformatics





University of Edinburgh

- Scottish Centre for Genome Technology and Informatics (GTI)
 - Peter Ghazal
 - Stuart Moodie
- Edinburgh Centre for Bioinformatics
 - Igor Goryanin
 - Anatoly Sorokin



Interferon Pathway Biology Project

- Interferon response pathway in macrophage
- Have collated >200 components of pathway from literature
- 3 years of MSc students
- Each interaction has provenance info
- Developing scoring scheme



Objectives

- To develop new approaches and understanding in Pathway Biology of infection and innate immunity
- Integration of HTP experimental data (high dimensional biology) with in silico pathway analysis
- Build a knowledge base using consensus pathway and logic interactions



Notation

- Use graphical representation of pathway
- Evolved a notation through use



Interferon Subcellular Logic Interaction Map

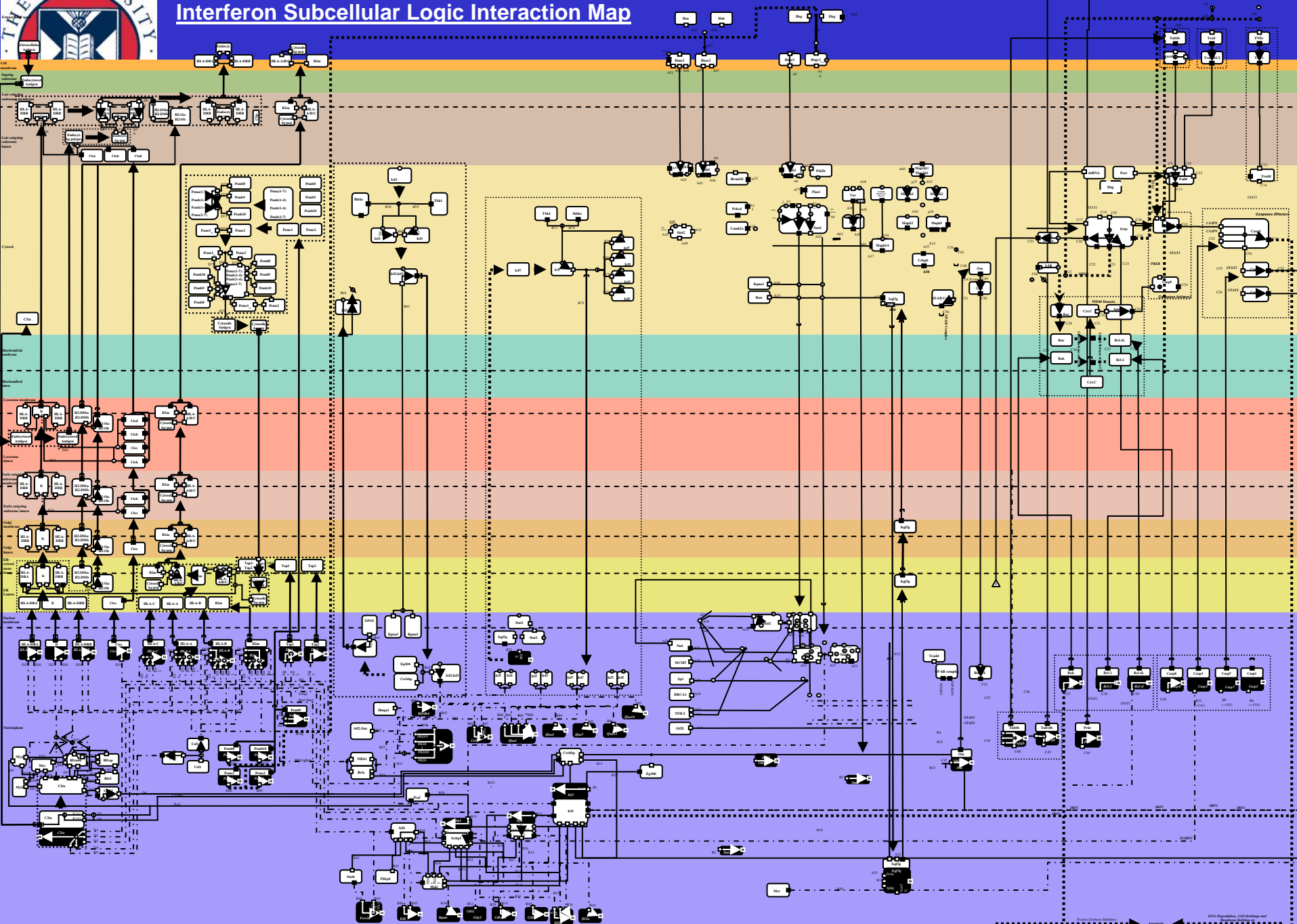

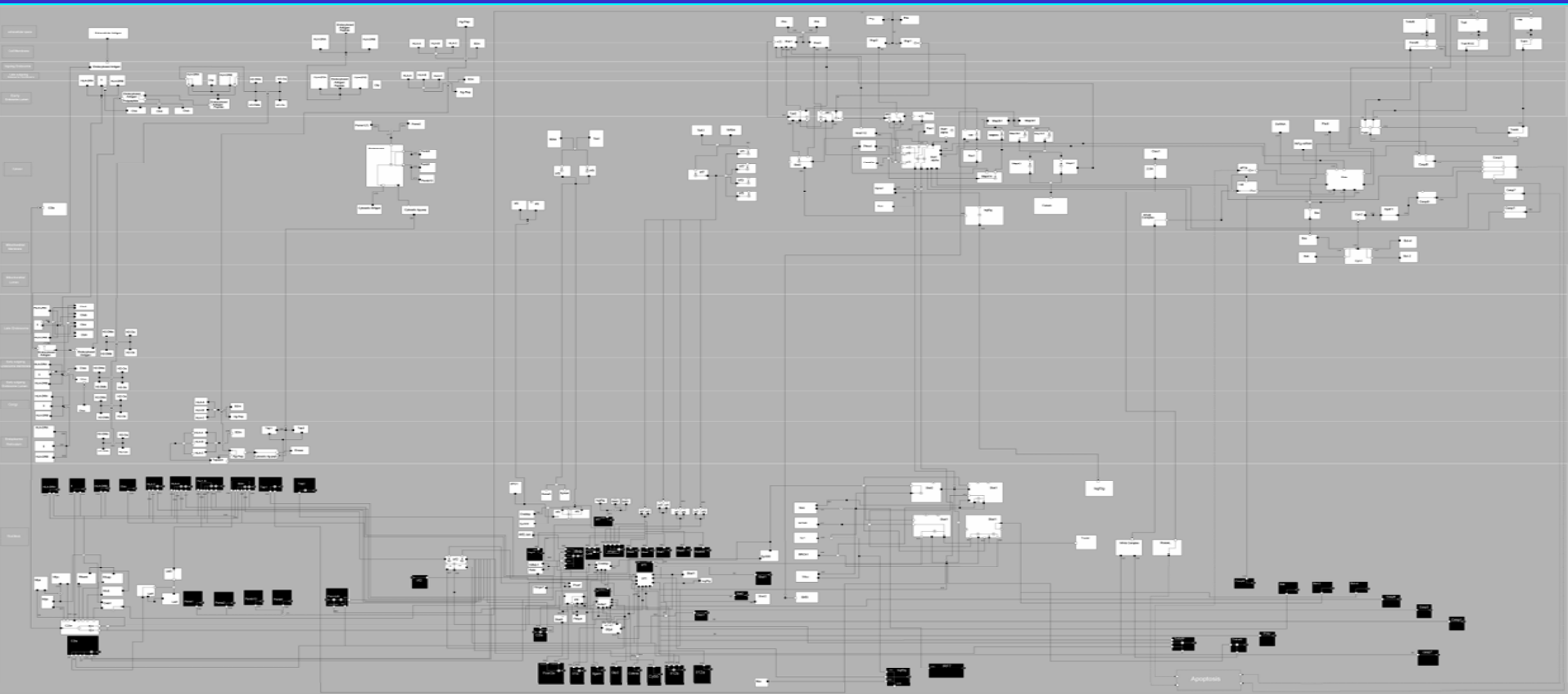

Edinburgh Centre for
Bioinformatics





Aims of Notation

- Accessible to biologists
- Described logic of interactions
- Compact
- Showed subcellular localisation clearly
- Tolerant of incomplete knowledge
- Computable
 - Software tools
 - Maps to SBML



Design Principles

- Describe state of interacting species
 - Localisation, Complexes, Activation, Modification
- Minimise redundancy
- Minimise number of symbols and concepts to remember
- Focus on logic



Different Views

Logical

Edinburgh Process Notation



Biochemical

Kitano/MIM

Metabolic



State Transition/Activation

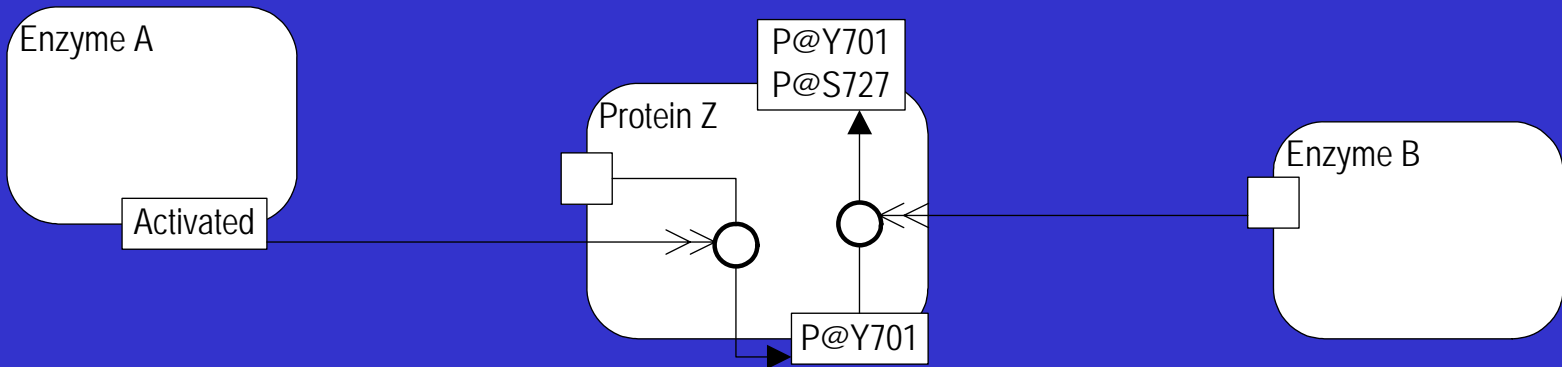



Logic Gates

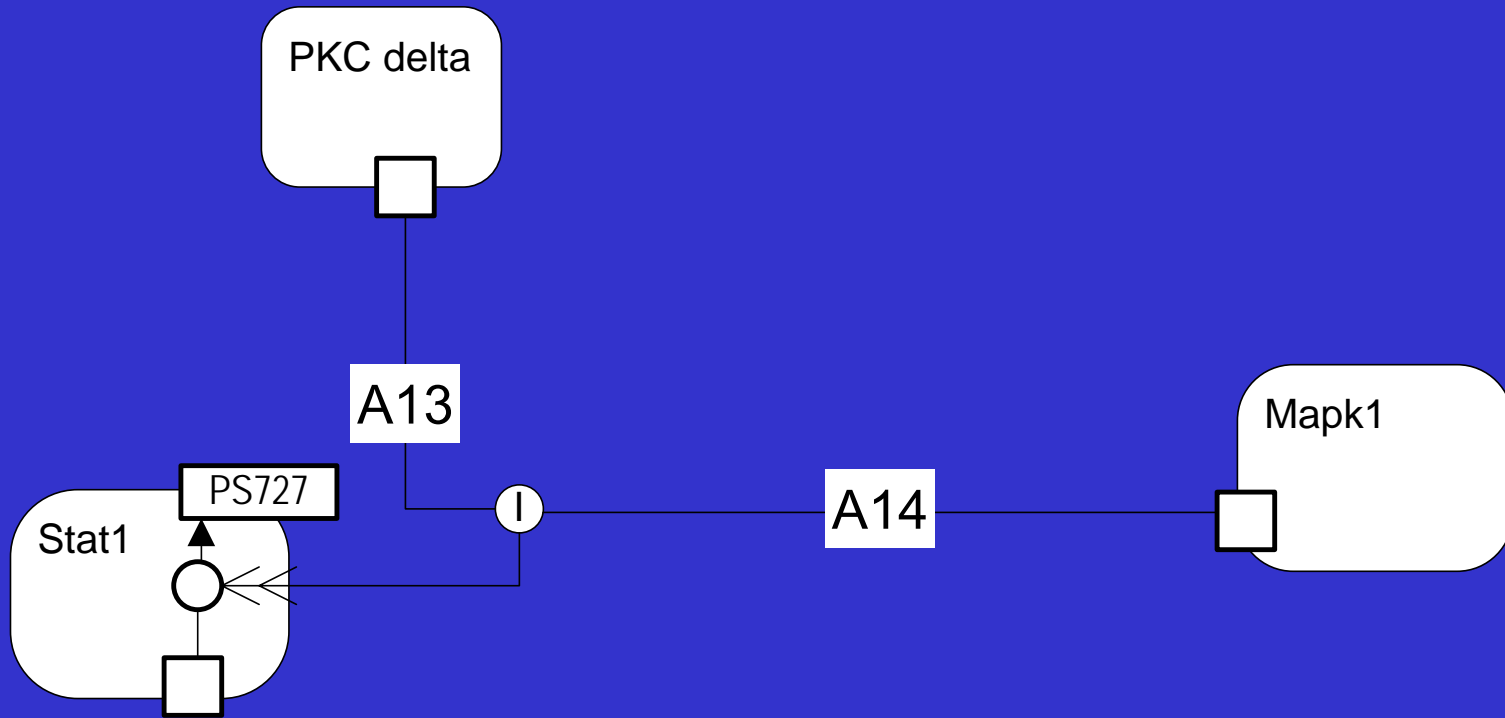



Complex Formation

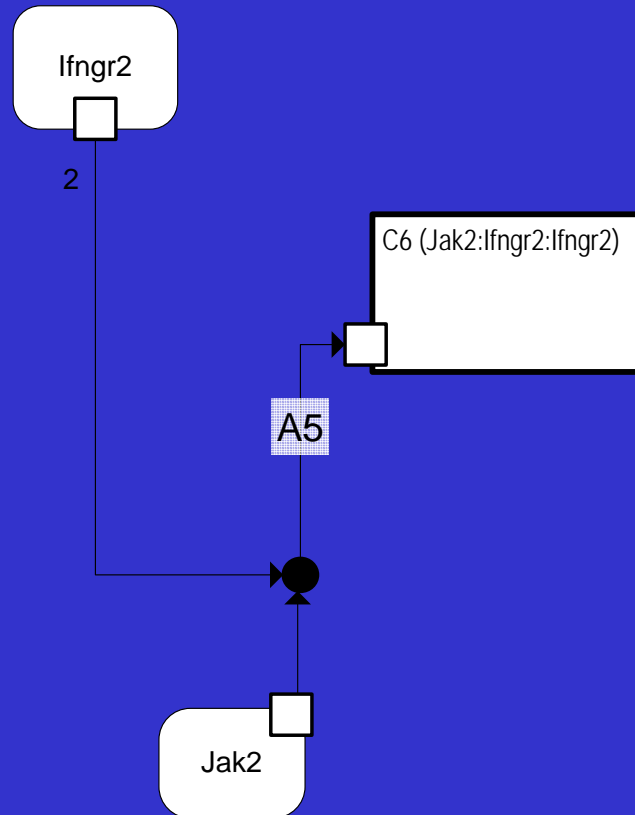



Gene Regulation

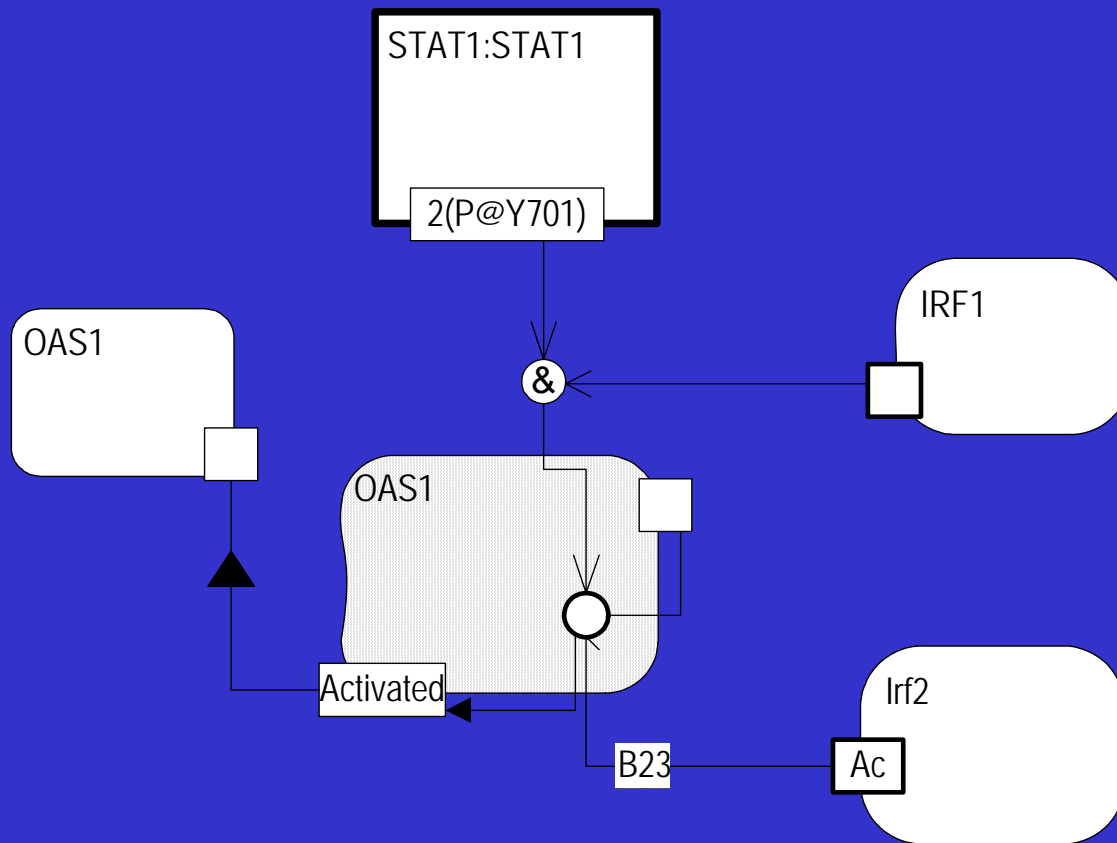



Gene Regulation: Multiple States

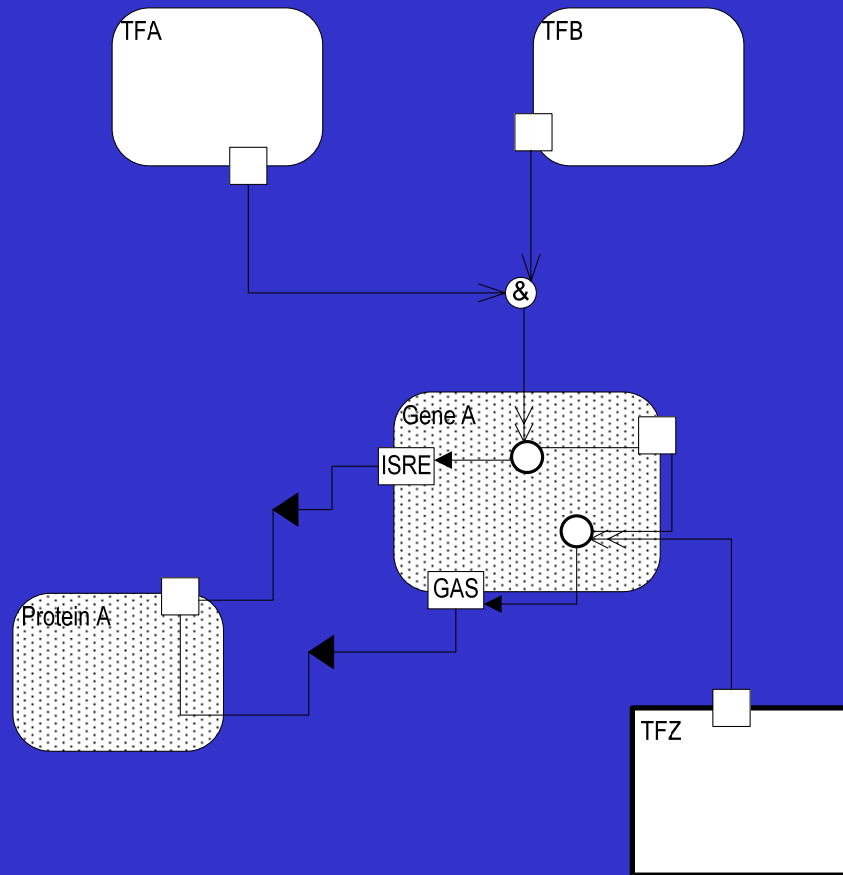



Localisation

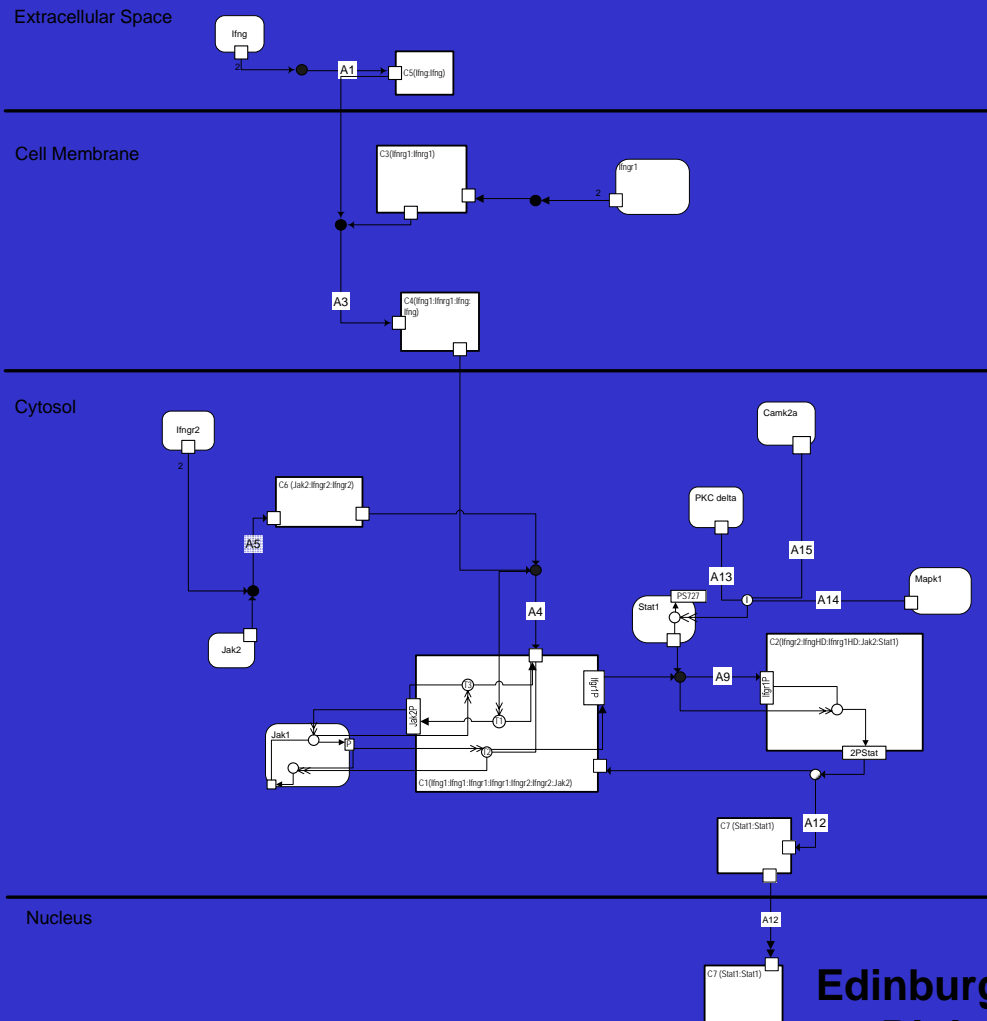

Outside



Inside



Symbols

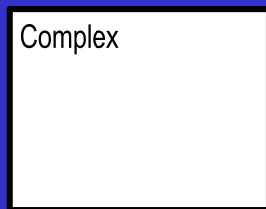
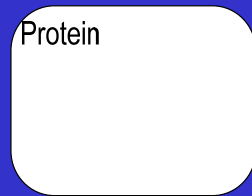
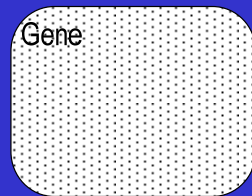

State

State
Transition

OR

AND

XOR

NOT

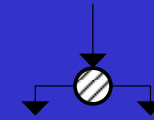
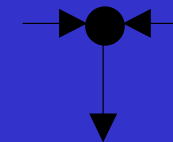

Absolute
Activation

Activation

Inhibition

Gene
Expression

Complex
Formation

Dissociation

Translocation



State transition: the hidden details

- Kitano process notation

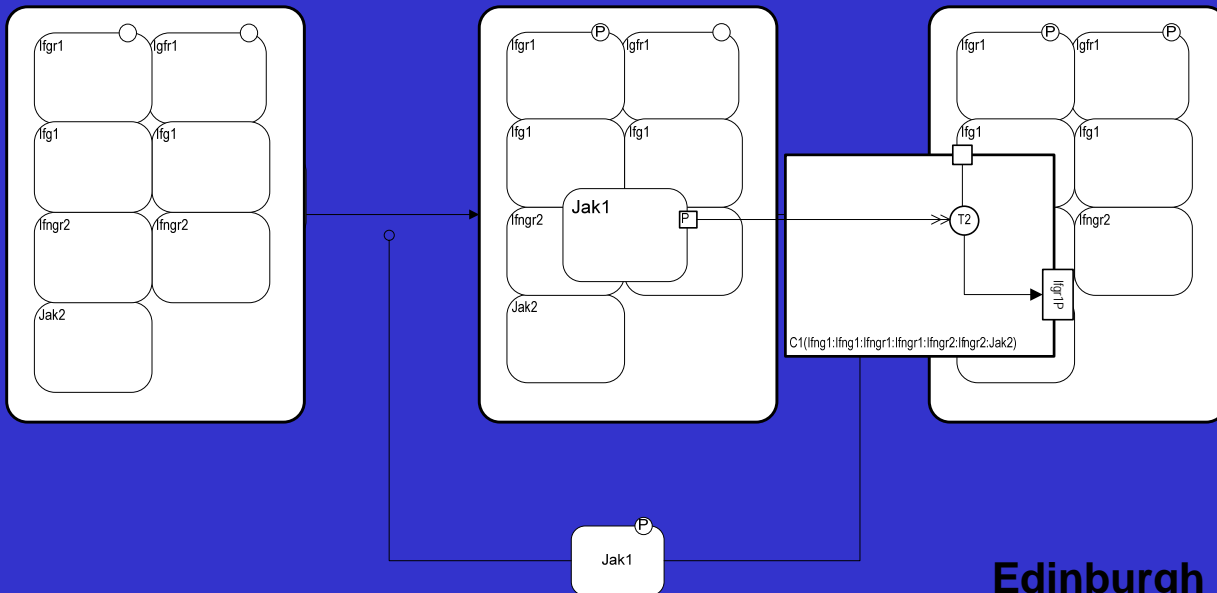



State Details

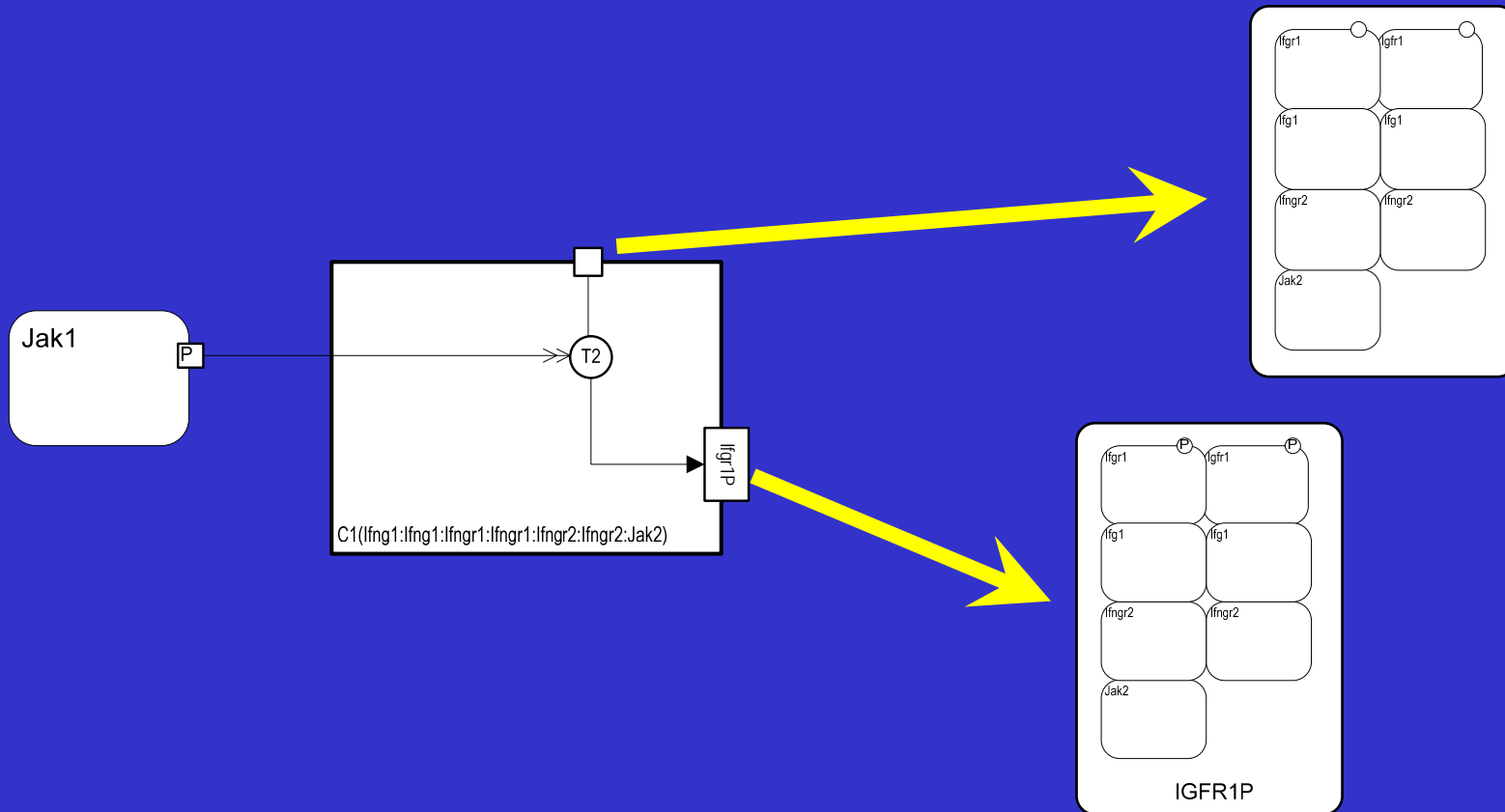



Complex Details

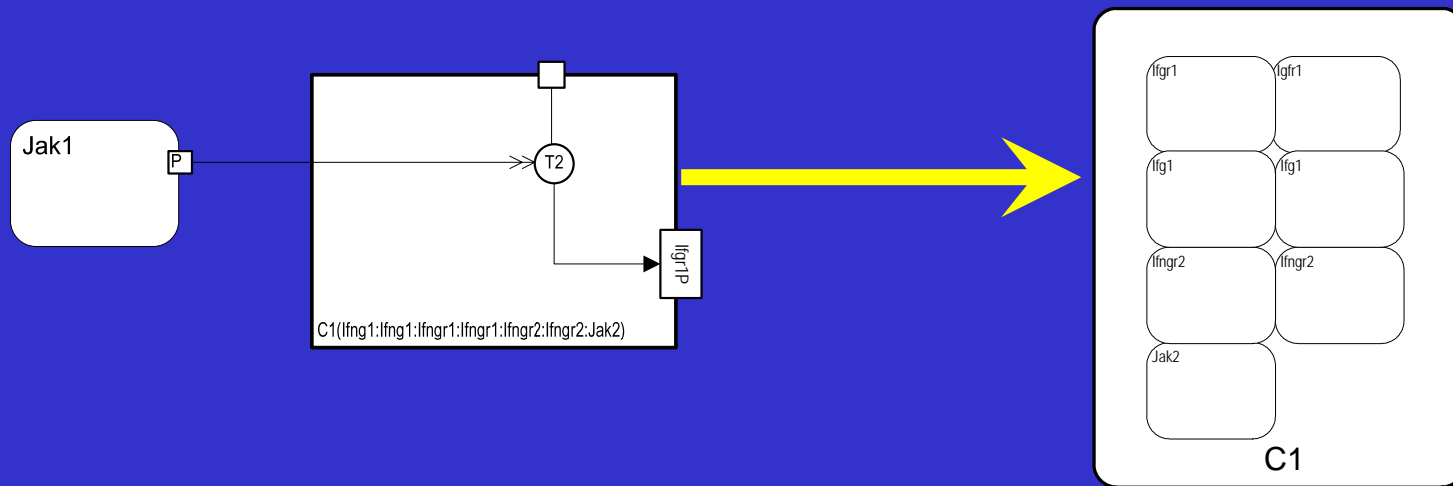



Tool Support: EPE

- Supports full notation
- Supports Kitano notation
- Hyperlinks to sub-diagrams
- Generates SBML map of notation



Jak/Stat

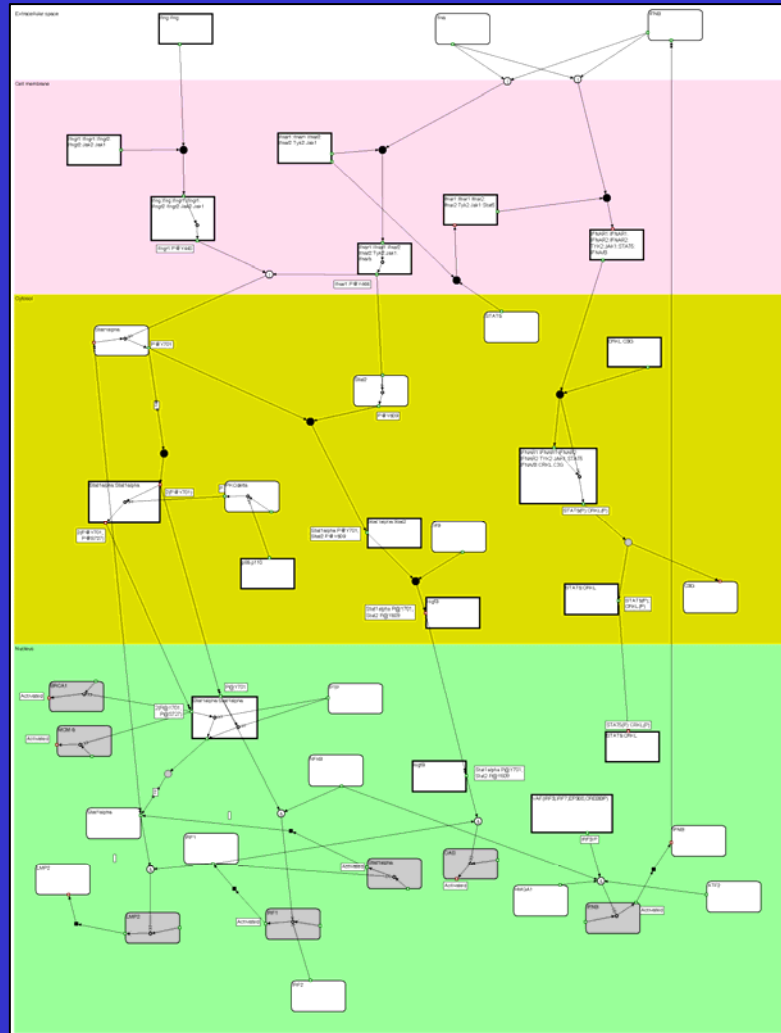

Edinburgh Centre for
Bioinformatics





Benefits

- Simple
- Compact
- Quick to draw large maps
- Enables hierarchical organisation
- Links to biochemical notation
- Software support



Future Work

- Continue “Field test” notation
- Metabolic pathways
- mRNA regulation (miRNA)
- Pathway “modules”



Acknowledgements

GTI

- Peter Ghazal
- Stuart Moodie
- Alan J. Ross
- Garwin Sing
- Kevin Robertson
- Paul Dickinson
- Graeme Grimes
- Thorsten Forster
- Douglas Roy
- John Beattie

ECB

- Igor Goryanin
- Anatoly Sorokin

Collaborators

- Dirk Husmeier
- Adriano Velasque
- Lily Cho
- Tobias Frankenberg
- Li-kun Phng
- Zhenjie Xu
- Lee Chuin Yao
- Alex Selkov



Questions?

**Edinburgh Centre for
Bioinformatics**

