

SBGN Activity Flow

SBGN-4

Oct. 16th-17th, 2008

Rostock, Germany

What is activity flow diagram

- A connection map between entities that displays the flow of activity.
- Ignores entity states and processes
- Widely used in research papers and textbooks.

Why activity flow in SBGN

- Survey to our curators in 2004.
 - Question: If you are a customer using our pathway website, how would you like the diagrams to be displayed.
 - 12 out of 13 said that they liked the way CellDesigner captured data, but would like to use a “reduced” diagram to display the results.
- PharmGKB
- Gene expression analysis
- Biology journals

AF for viewing only

- Activity flow is only for viewing purpose.
- PD or ER should be used to edit or curate the pathways.
- Rules should be defined to convert PD or ER to AF.

Hybrid diagram

- Do we allow hybrid diagram if rules can't be defined for the automatic conversion?
- AF hybrid with PD?
- AF hybrid with ER?

User define rules?

- Can user draw both PD and AF, and specify which part of the PD correspond to AF?

User generate AF diagram?



- AF is not a reduced view of PD or ER
- AF can be generated from PD or ER.
- Users should be allowed to create AF diagram.

- Nodes in AF do not represent entity pool, but activity.
- Edges
- Each node represents one activity.

Proposal I

Positive
influence



Negative
influence



Proposal I

Proposal II

Positive
influence



Negative
influence



Unknown
influence



Unknown

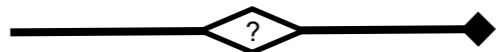

Proposal I

Proposal II

Positive
influence



Negative
influence



Unknown
influence



Unknown



Better terms
for these?

Proposal I

Proposal II

Proposal III

Positive
influence

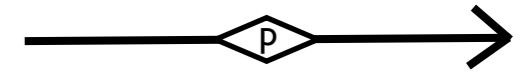

Negative
influence



Unknown
influence



Unknown



Better terms
for these?

Proposal I

Proposal II

Proposal III

Positive influence

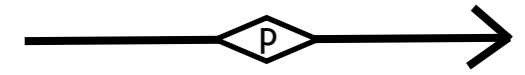

Negative influence



Unknown influence



Unknown

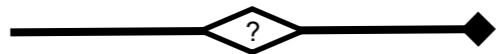

Better terms for these?

These notations are used in (stimulation and inhibition)

Proposal I

Proposal II

Proposal III

Positive
influence

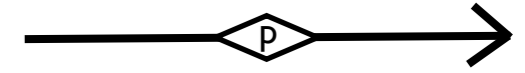

Negative
influence



Unknown
influence



Unknown



Better terms
for these?

These notations are
used in (stimulation
and inhibition)

Only the protein
state is considered

Proposal I

Proposal II

Proposal III

Positive
influence

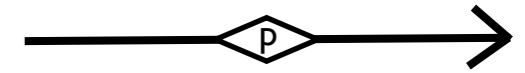

Negative
influence



Unknown
influence



Unknown

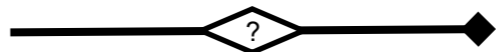

Better terms
for these?

These notations are
used in (stimulation
and inhibition)

Only the protein
state is considered

Both states and
modifications are
displayed

Activation

-Rule I

- If reactant is inactive, and product is active, and the modification is catalysis, stimulation, modulation, use activation.
State and modification will not be illustrated in activity flow diagram

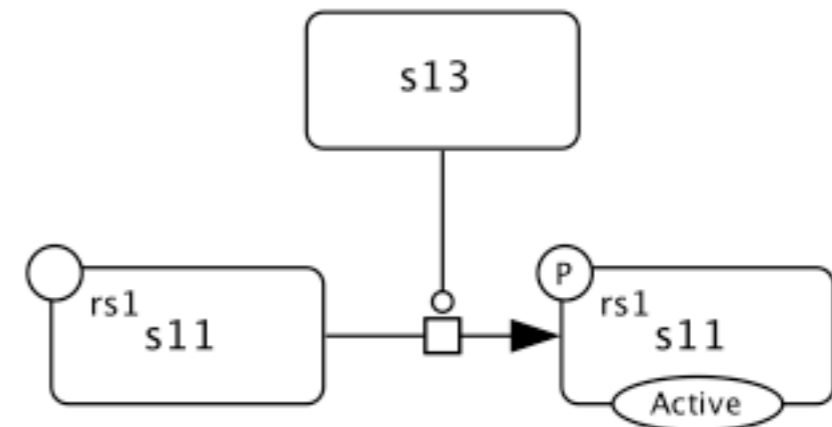
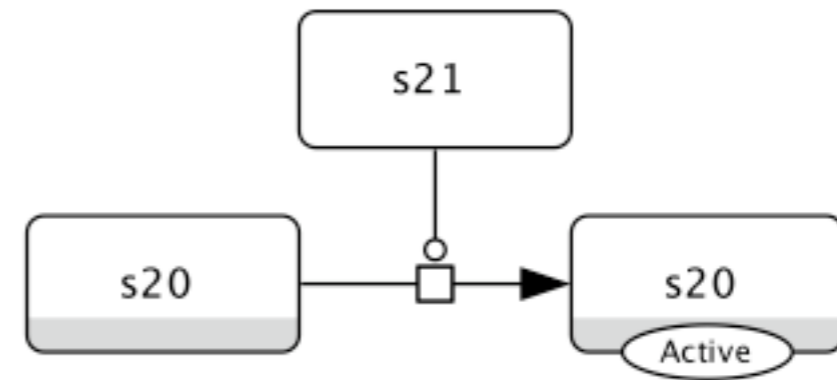
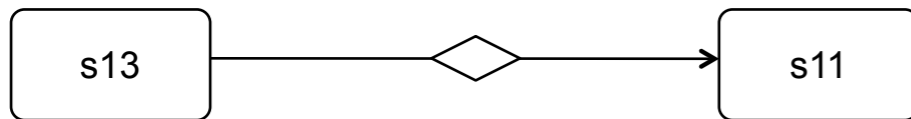
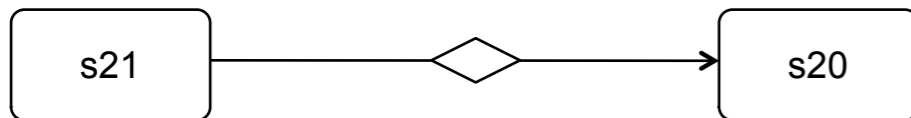

Activation

-Rule 2

- If the reactant is active, the product is inactive, and the modification is inhibition, use activation.
State and modification will not be illustrated in activity flow diagram

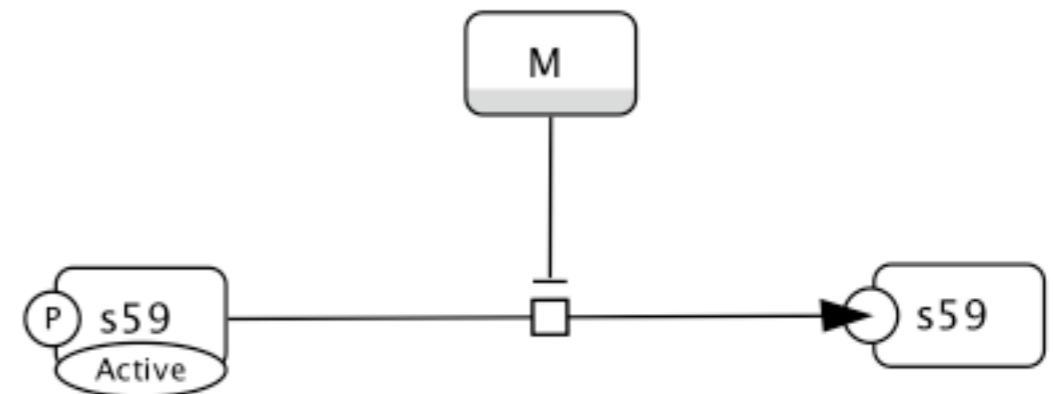
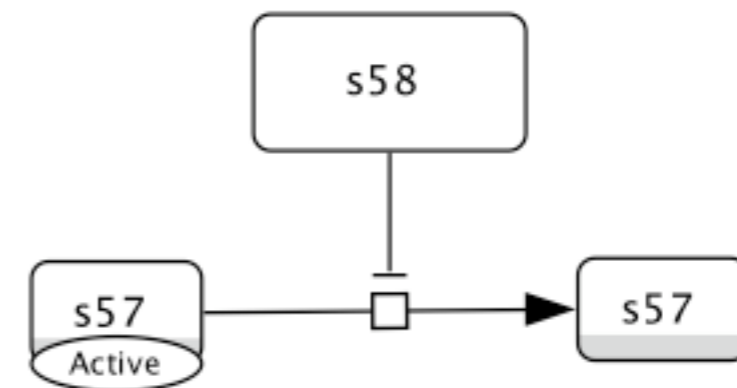
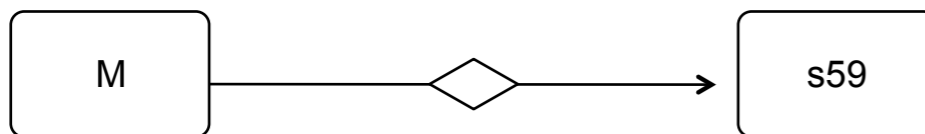
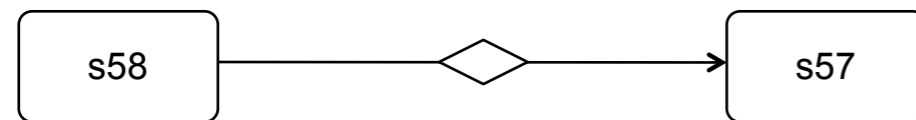

Inactivation

-Rule I

- If reactant is inactive, the product is active, and modification is inhibition, use inhibition State and modification will not be illustrated

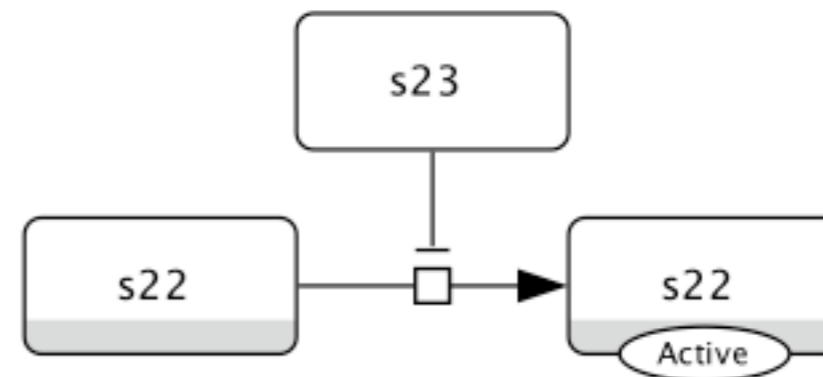
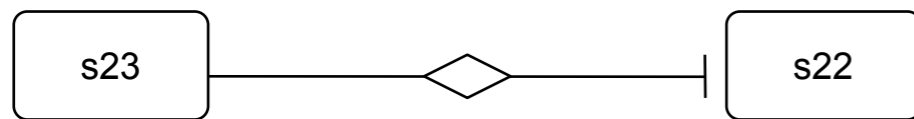
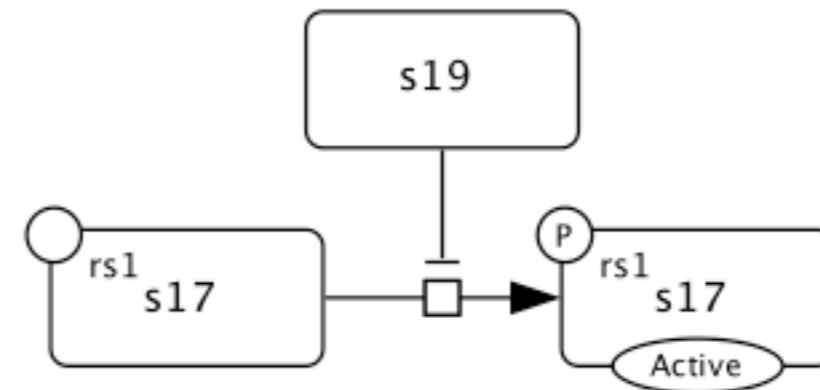
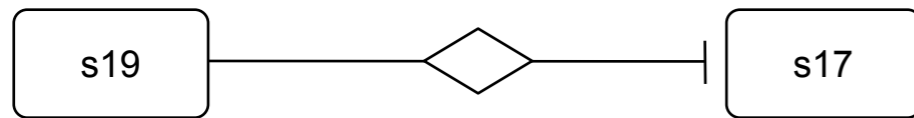

Inactivation

-Rule 2

- If the reactant is active, product is inactive, and the modification is catalysis, modulation or stimulation, use inhibition. State and modification will not be illustrated.

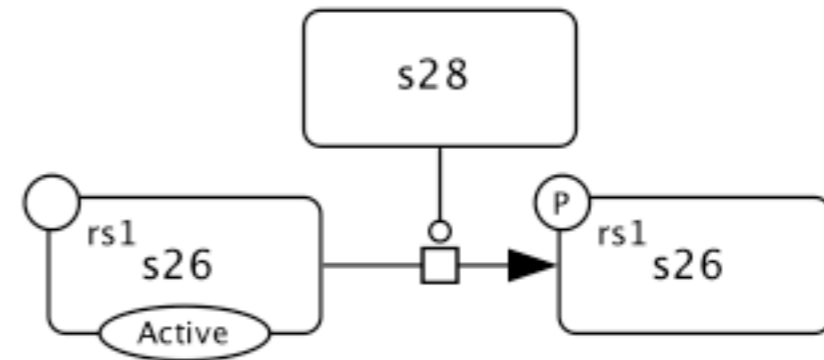
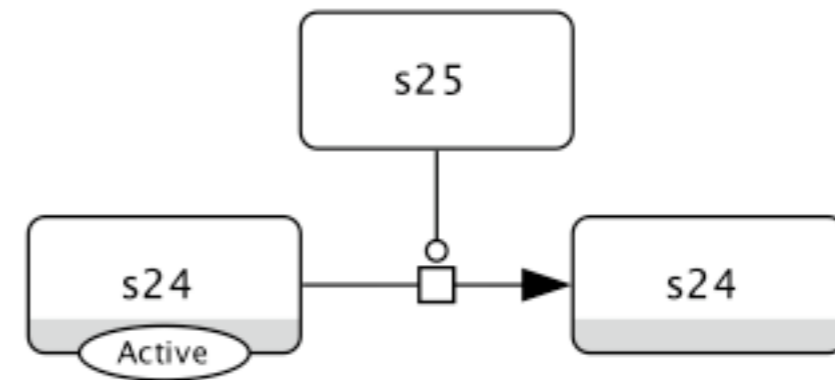
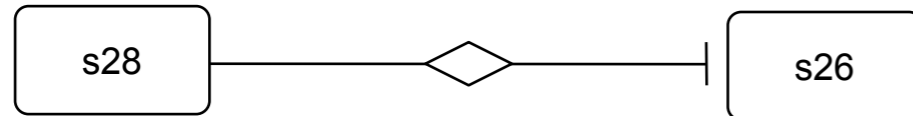
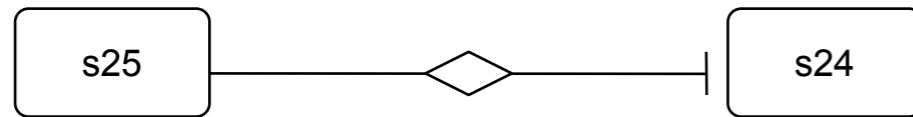

Neutral

- If reactant and product have the same active state, use neutral. State and modification will be not illustrated in activity flow diagram.

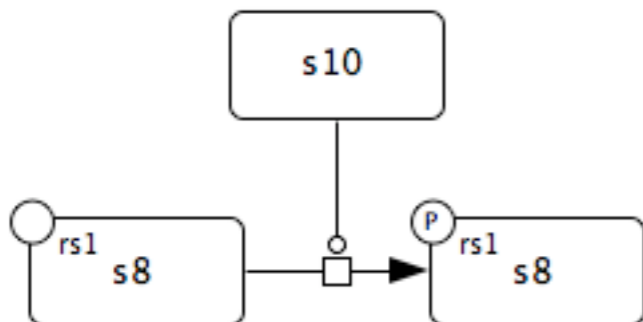
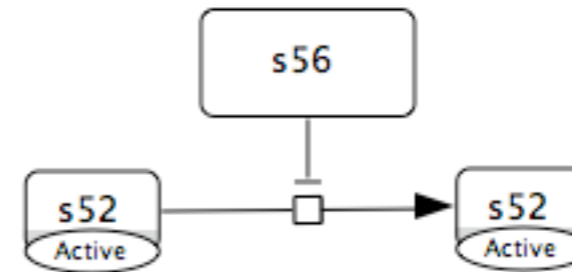
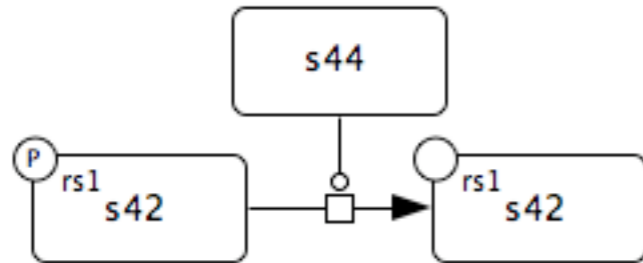
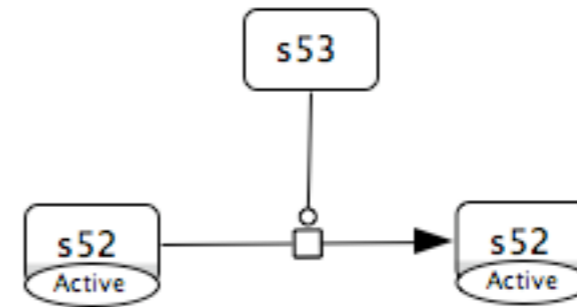
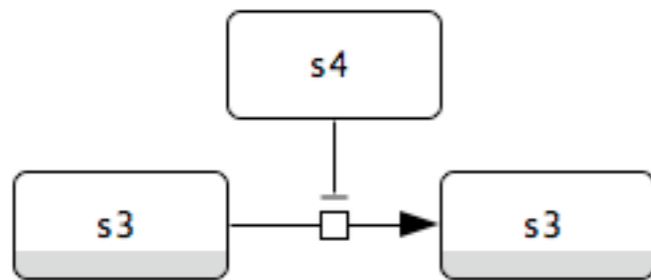

Unknown

- If transition is unknown in PD, use unknown. State and modification will not be illustrated.

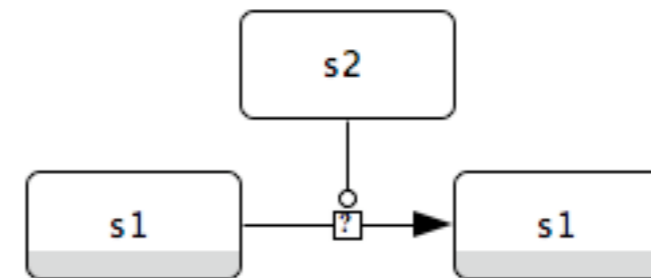
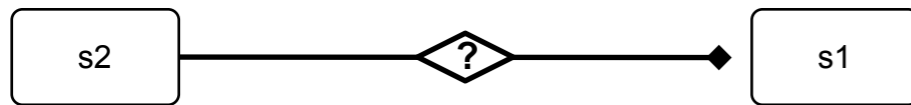

Special cases

- Receptor binding

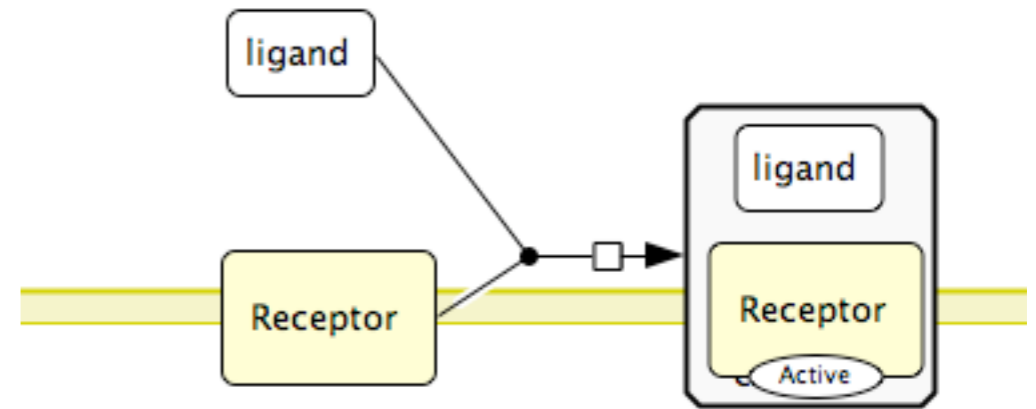

Special cases

-Proteolysis

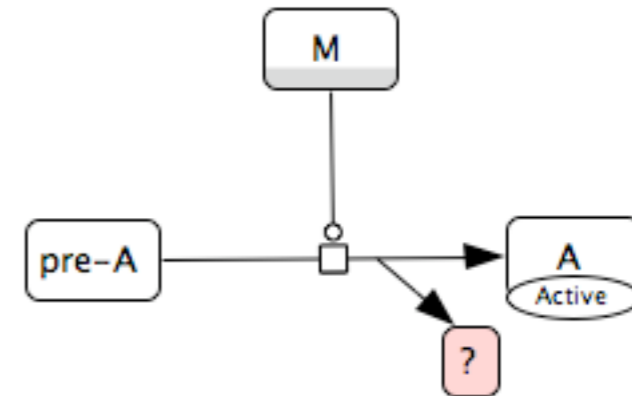
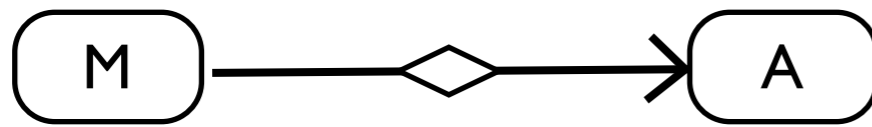

Special cases

-Degradation by ubiquitination

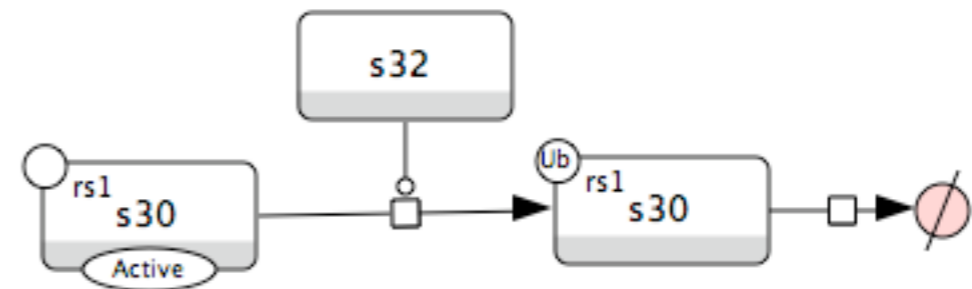
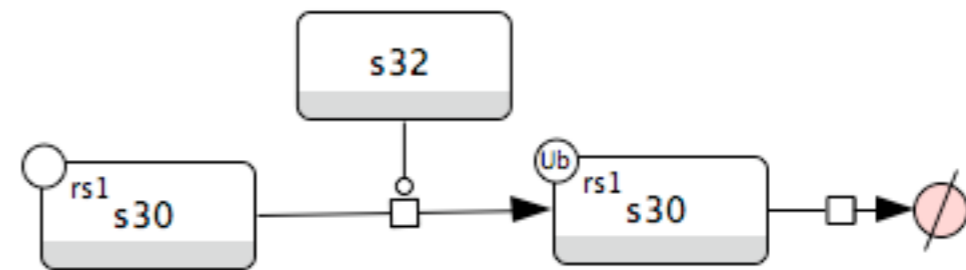

Special cases

-Bidirectional reactions

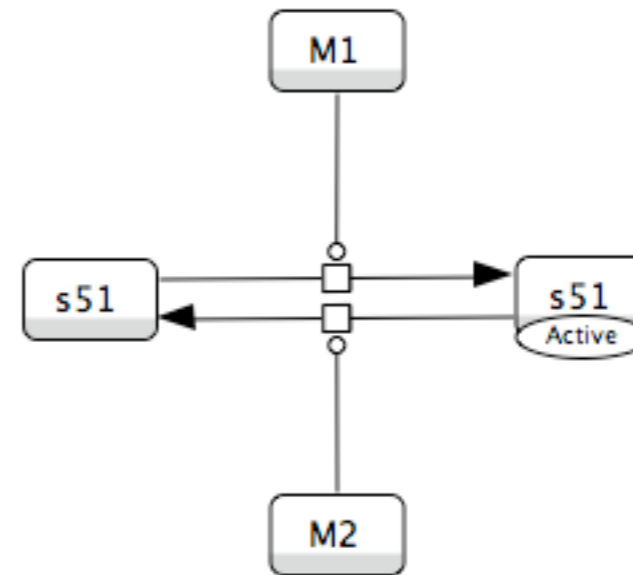
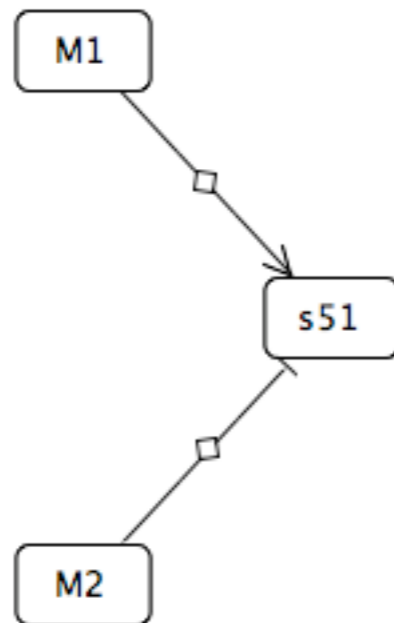

Special cases

- Complex formation

Use logic gate

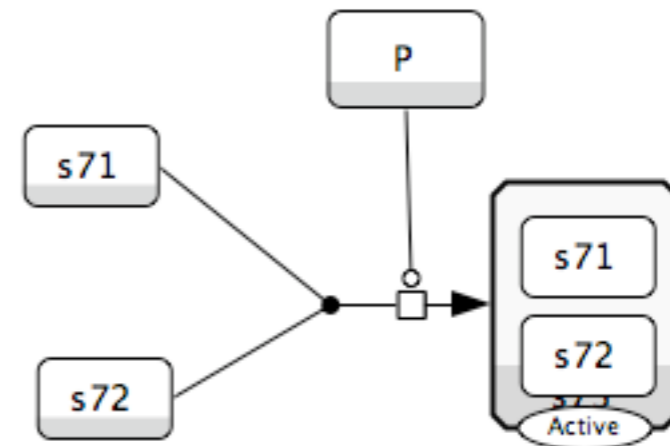
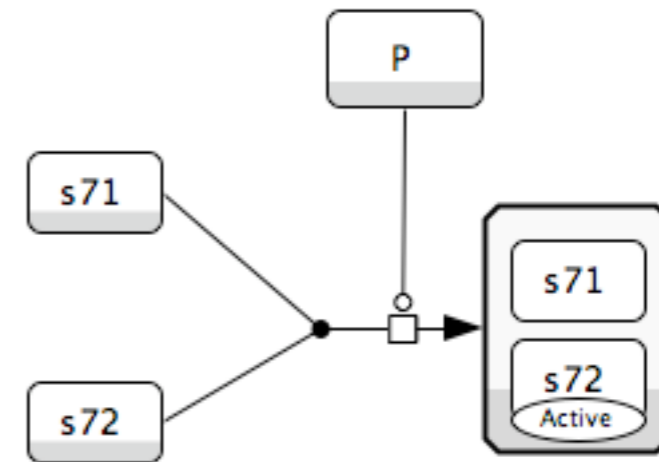

Special cases

-Sequential reaction

Use logic gate

