

ER (MIM) in SBGN Level 1

Symbols

The “copy” isolated dot

Assignments: multiple values

Interpretations

Explicit definition in SBGN?

User-specified container nodes?

Outcome = A complex of histone H3 and H4

Copy = A second copy of the above (copies the entity on the other side of the interaction)

Outcome = a tetramer: two [histone H3:H4]

“COPY”?

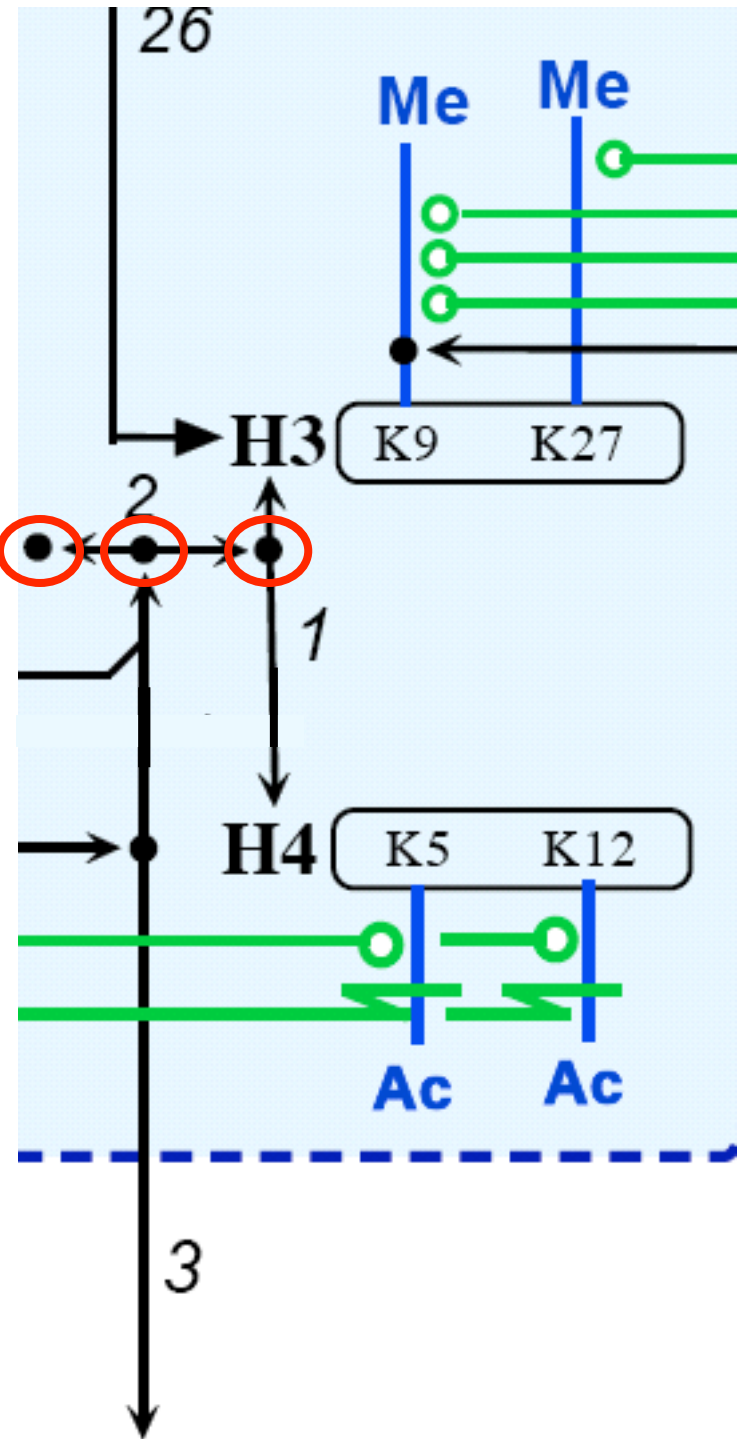

DNA damage (ATM, DNA-PK, ATR)

Explicit MIM: p53-MDM2-MDMX

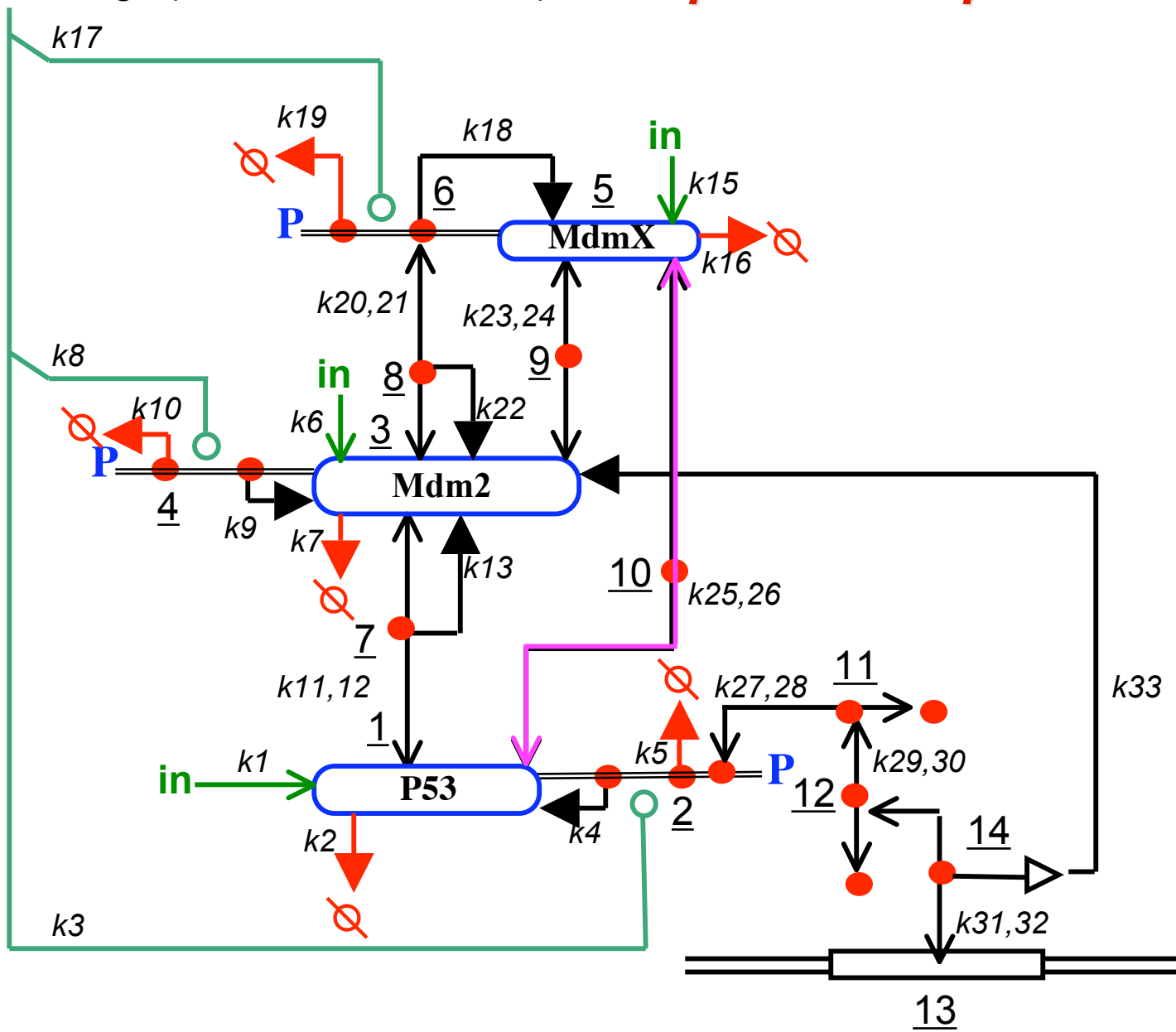

Kim et al., unpub.

P53 Tetramer

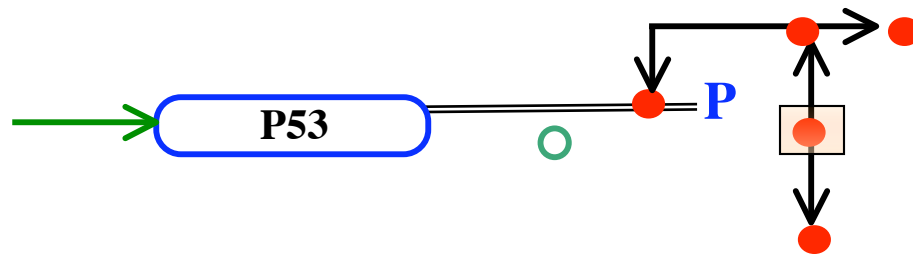
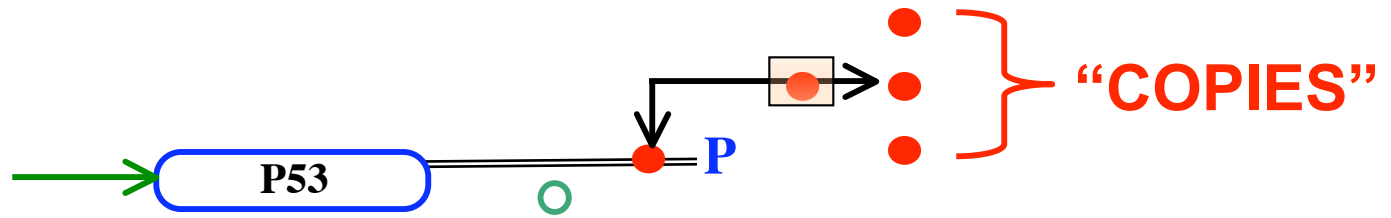

Expanding the Assignment Arc: Multiples

Those two outcomes have very different interactions with TFs

These two outcomes are very different too

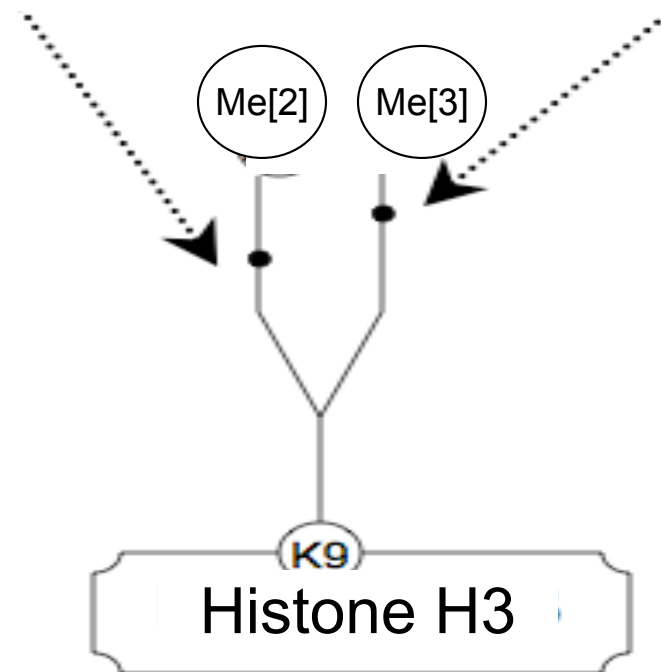
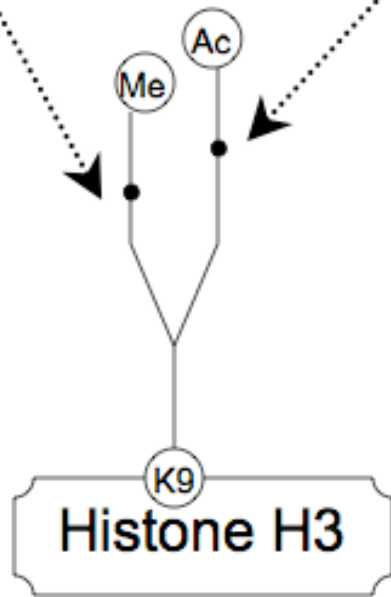

?

(other examples: Ub)

The above situation can be depicted by assignments

Interpretations:

MIMs can be interpreted in 3 ways:
explicit, heuristic and combinatorial.

A Heuristic or Combinatorial MIM

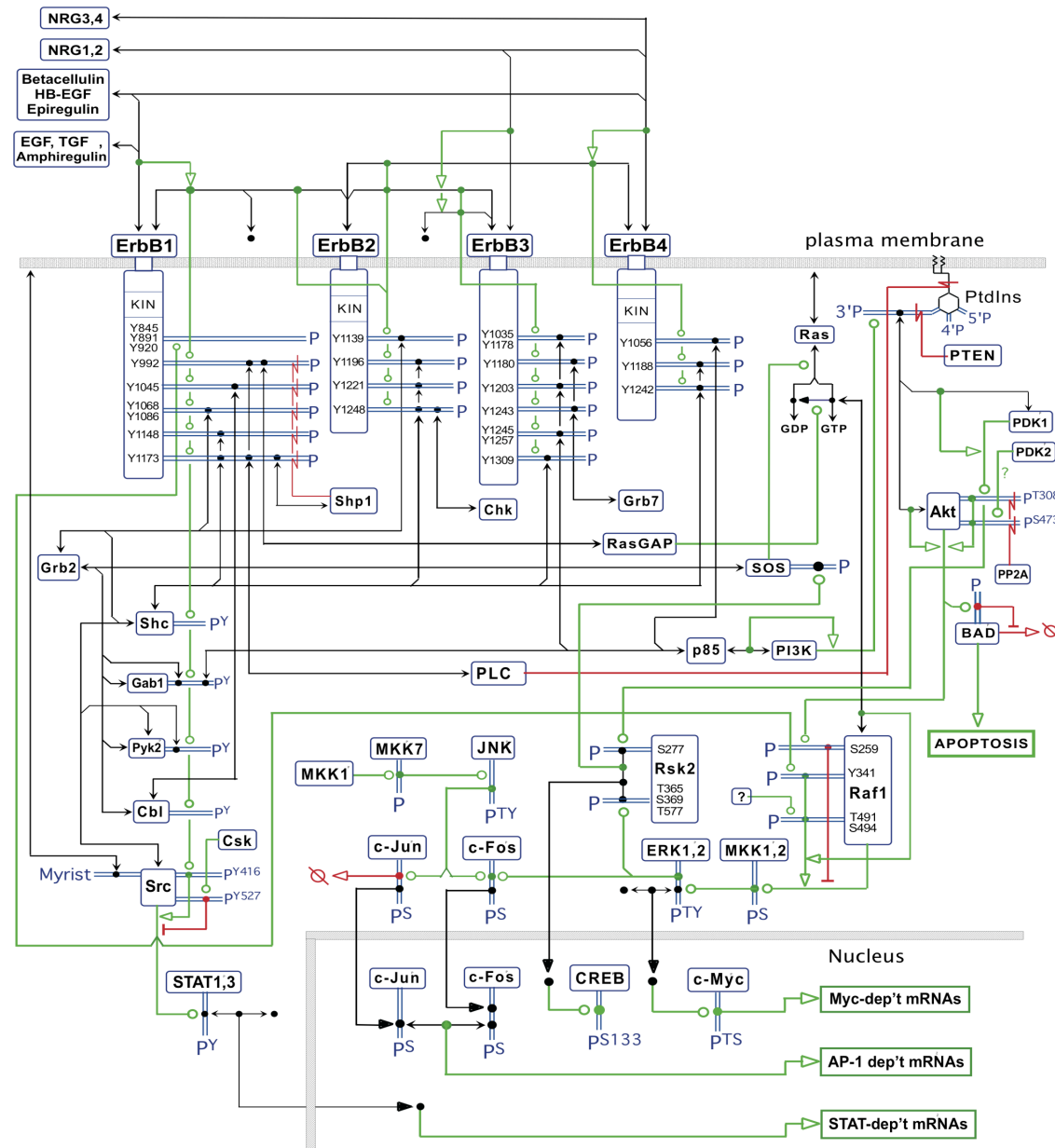

Interpretations:

MIMs can be interpreted in 3 ways:
explicit, heuristic and combinatorial.

Should these interpretations be
mentioned in the SBGN specs or left
for users' discretion?

The Use of Container Nodes:

ER diagrams do not require containers for complexes, since complexes are drawn explicitly .

However, it might be useful to adapt complex-type containers to depict macromolecules with multiple domains (e.g. across cellular compartments)

Can such flexibility be supported? (OK with decisions accepted 1/29/08 allowing subunits to be linked to modulation arcs)

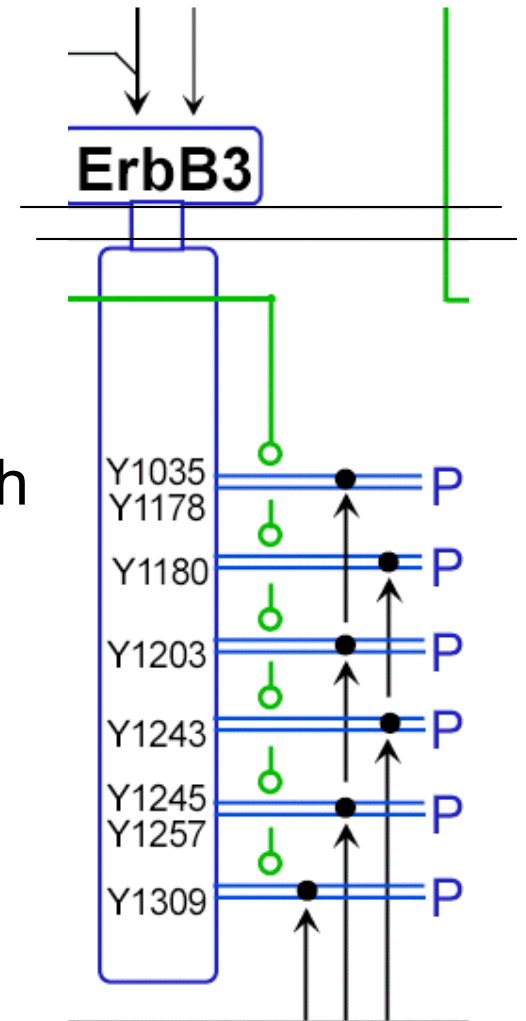

**THANK
YOU!**